

*KNOW-HOW SAVES YOU MONEY*

[www.kolev.com](http://www.kolev.com)



**GUARANTEE at least 10% lower price on new roll forming lines in North America**





## What do you need to know when purchasing a Roll forming machine or a complete Roll forming line.

(continue)

### • What do I need to complete my ENTRY SYSTEM

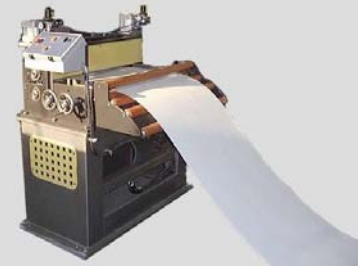
Entry system in a Roll forming line covers the following equipment:

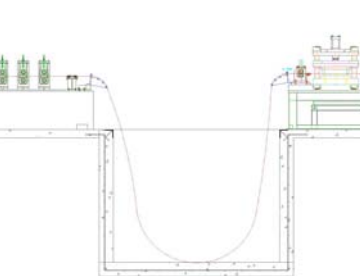
ENTRY system machinery	Features	View
a. Uncoiler	<ul style="list-style-type: none"> <li>• Single or double mandrel</li> <li>• Capacity – 1,5 ton – 15 ton</li> <li>• Mandrel length - 300mm to 1300mm</li> <li>• Mandrel manual or hydraulic expansion</li> <li>• Rotation – manual or hydraulic</li> <li>• Feed up or Full time drive</li> <li>• Hold down arm</li> <li>• Coil keepers</li> <li>• Shock absorbers</li> <li>• Dancer arm – loop control</li> <li>• Mandrel leaf risers – encrease coil ID</li> </ul>	
b. Coil car	<ul style="list-style-type: none"> <li>• Capacity – 5 ton to 10 ton</li> <li>• Hydraulic elevation</li> <li>• V-cradle</li> </ul>	

<p>c. Peeler table</p>	<ul style="list-style-type: none"> <li>• Material thickness - 3 to 6mm</li> <li>• Material width - 350mm to 700mm</li> <li>• Mounting - stand alone or machine mounted</li> <li>• Motion - Up/Down, Extend/Retract</li> </ul>	
<p>d. Flattener</p>	<ul style="list-style-type: none"> <li>• No. of straghtening rolls – 5,7,9,11</li> <li>• Straightening rolls Diameter – 50mm to 100mm</li> <li>• Width – 300mm to 550mm</li> <li>• Pinch rolls – entry and exit</li> <li>• Back up rolls</li> <li>• Drive capacity – 3 to 20 kw</li> <li>• Maximum speed – 30 mpm to 150 mpm</li> </ul>	
<p>e. Pre-punch press with servo feeder</p>	<ul style="list-style-type: none"> <li>• Presses capacity – from 10 ton to 140ton</li> <li>• Press type – mechanical, hydraulic</li> <li>• C-type, 4 post</li> <li>• Strokes per minute – 50 to 100</li> </ul>	
<p>f. Loop control</p>	<p>Location</p> <ul style="list-style-type: none"> <li>• Between Uncoiler and roll former or flattener,</li> <li>• between flattener and pre-punch press</li> <li>• Between pre-punch press and roll former</li> </ul>	
<p>g. Pit</p>	<ul style="list-style-type: none"> <li>• Hole in the ground for feed synchronize at entry and exit side of pre-punch press</li> </ul>	
<p>h. Lubrication system</p>	<ul style="list-style-type: none"> <li>• Oil base roller applicator</li> <li>• Material width – 300mm to 1200mm</li> </ul>	 <p>“UNIST” lubrication system</p>

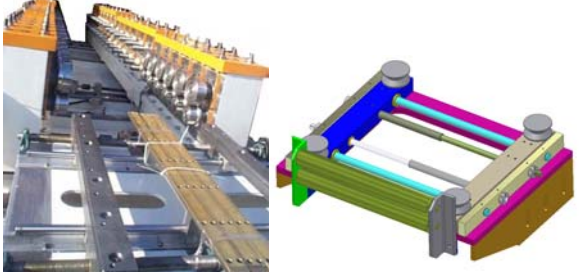
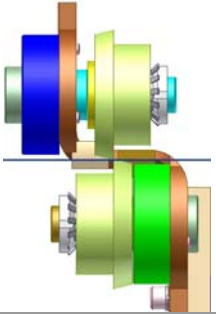
<p>i. Entry guide at the roll former entry</p>	<ul style="list-style-type: none"> <li>• Guide type Roller Slide Chain</li> <li>• Adjustment Center Compatible Non center compatible Manual</li> <li>• Max material width – 300mm to 1200mm</li> <li>• Max material thickness – 3mm to 6mm</li> </ul>	
<p>j. Rear cutter</p>	<ul style="list-style-type: none"> <li>• Used in panel lines to cut material prior to storage left over coil or coil change from one profile to another</li> </ul>	

For technical expertise - call KOLEV @ 905 751 0339 or send us an e-mail: [sales@kolev.com](mailto:sales@kolev.com) .  
 We will help you to put together your custom roll forming line.

NEXT:  
 What do I need to complete my exit system?

Zdravko Georgiev P.Eng (Dako)